

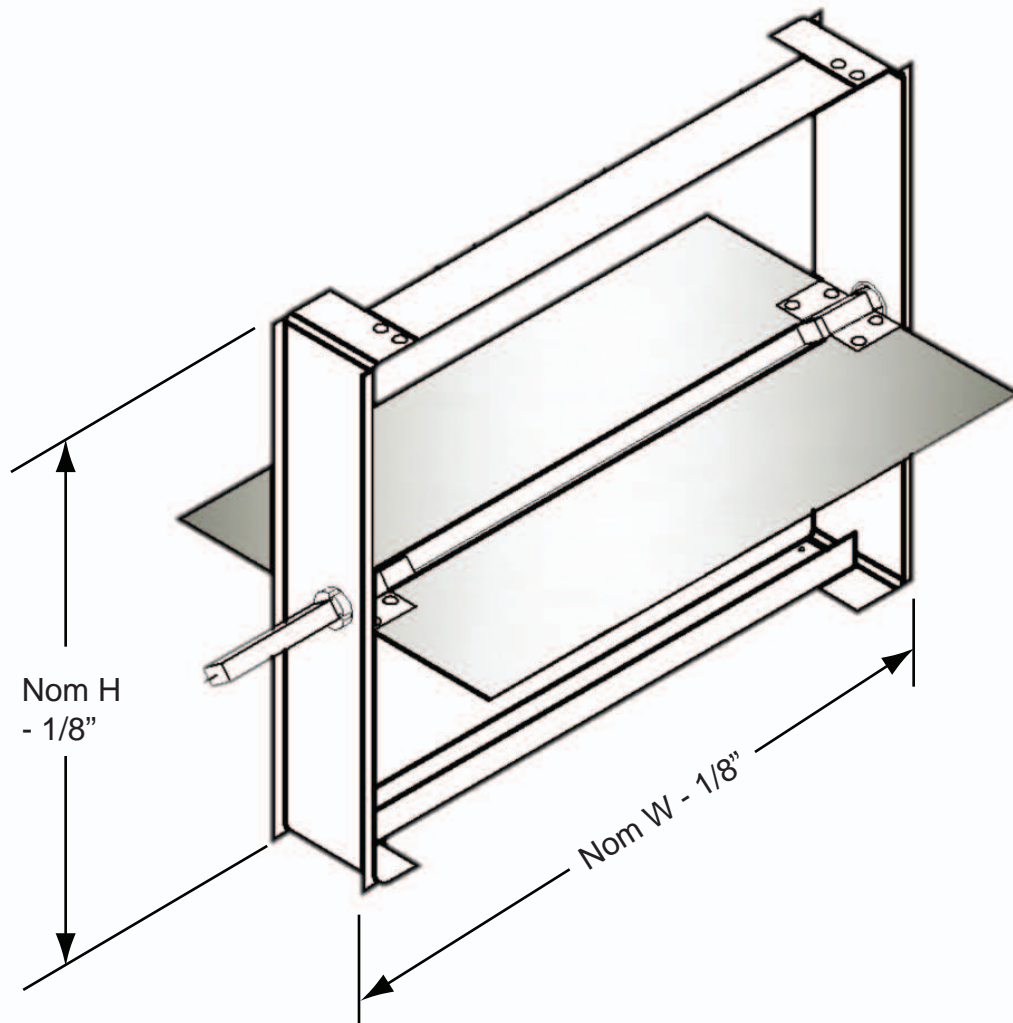

PRODUCT FEATURES

- Square / Rectangular balancing damper for remote adjustment of air flow feeding air outlets.
- Single, 18 gauge blade with V groove design for increased rigidity.
- Single damper sizes from 4" x 4" to 24" x 18". Sizes wider than 24" will consist (2) dampers welded together with a single drive shaft.
- 3/8" square damper shaft in molded synthetic bearings.
- Operating range up to 2" w.g. (not full shut-off).
- Damper used with Zipset Actuator Model ZSA-1R.
- Actuator and Anti-rotation bracket are field installed to side of the duct after damper installation.



PROJECT :

SUBMITTED BY: