



PRODUCT FEATURES

- Round balancing damper for remote adjustment of air flow feeding air outlets.
- Single, round 20 gauge blade with V groove design and ribbed cylinder for increased rigidity.
- Nominal diameters from 04" to 20".
- 3/8" square damper shaft in nylon bearings.
- Operating range up to 2" w.g. (not full shut-off).
- Damper used with Zipset Actuator Model ZSA-1R (actuator can be factory installed or field installed).
- No blade stops used - eliminates issues with improper synchronization of damper and actuator position during actuator installation.
- Actuator anti-rotation bracket factory installed on all ZIL-ST dampers.



HEAVY DUTY CONSTRUCTION



ZIL-ST SHOWN WITH ACTUATOR ATTACHED

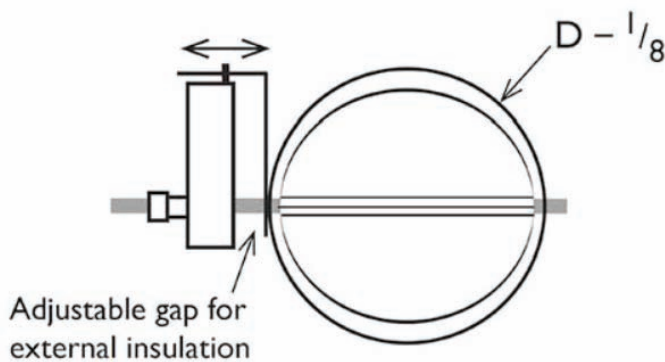
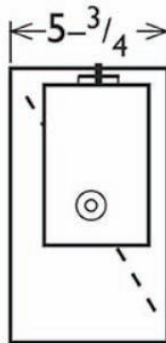

PROJECT :

SUBMITTED BY: